

GROOVED END

- Body construction 111 Grooved end 3"-8"
- Face to face MSS SP-67 table 4
- Groove acc. to AWWA C606
- Top flange EN ISO 5211
- Max working pressure PN 16
- Temperature range -20°C + 140°C according to material
- Operation Handwheel
Lever
Electric actuator
Pneumatic actuator
- Coating Epoxy min 80 micron UV resistance
- Disc Bronze/ Ductile Iron rubber vulcanized EPDM/ NBR/ Hypalon/ Butyl
- Tightness test According to EN 12266-1:2003
- Material certificate EN 10204.3.1



Materials

Item	Description	Material
1	Body	Ductile Iron
	Option Lining	Rilsan/ Halar
2	Disc (vulcanized)	As specified above
	Option Lining	EPDM/ NBR
3,4	Shaft	SS316/ SS420/ Duplex
4	Axle	
5,6	Bushing	Brass/ Nylon 11
7	Washer	Galvanized Steel
8	Sealing Ring	Fiber
9	O-Rings	NBR/ EPDM
10	Circlip	Steel Spring
11	Woodruff Key/ Rectangular Key	Steel

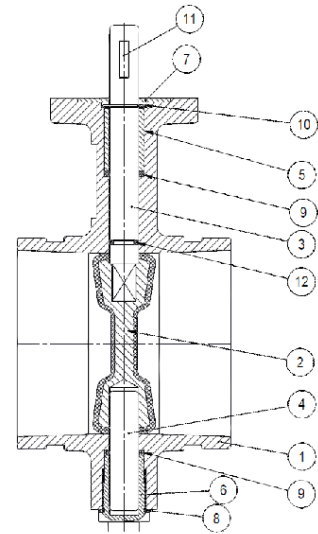

Dimensions

	80	100	150	200
mm	80	100	150	200
inch	3"	4"	6"	8"
A	120	135	176	202
B	87	104	147	170
C	97	116	148	133
D	88.9	114	168.3	219
D1	84.8	110	163.8	214.4
M	7.8	9.4	9.4	11.9
ds	15.87	15.87	25.4	28.6
hs	5	5	6	6
h1	18.4	18.4	28.4	31.6
N	16	16	16	19
E	42	42	62	62
EL	37	37	35	35
F	265	265	354	354

